



**INTERNATIONAL JOURNAL OF ENGINEERING SCIENCES & RESEARCH
TECHNOLOGY**

**DESIGN AND DEVELOPMENT OF AUTOMATIC AND PORTABLE INSULIN
SYSTEM BASED ON MSP430 MCU**

Bhosage Prasad P.*, Gote Akash.A., Yerikar Rohit H.,Vhatkar Niranjan A.

Department of Electronic & Telecommunication Engineering.
Brahmdevdada Mane Institute of Technology, Solapur, India

ABSTRACT

Since manual method of micro or nano flow-rate of liquid handling is inaccurate and tedious job, the automated micro flow-rate liquid delivery system is suitable. In this paper the best approach towards development of practical approaches to liquid-delivery system for micro flow-rate with accuracy and precision is presented. The experimental and results demonstrate that the liquid-delivery system is capable of generating accurate and condition-independent micro- and nano-flow rate.

KEYWORDS: Electronic Instrumentation, Syringe Pump, Artificial Pancreas Control..

INTRODUCTION

Diabetes mellitus is a chronic metabolic disorder and it is characterized by the disability of the body to maintain the blood glucose levels into physiological ranges. It is an autoimmune disease in which the beta- cells of the pancreas are destroyed, resulting in the absence of insulin secretion. Purpose of create, design and development of portable insulin delivery is to delivered the precise and also accurate dosage of insulin to the diabetes patients. Thus the portable insulin syringe is having advantages of low cost and simple for operate.

Thus in the portable insulin syringe the infusion rate plays an important role. Insulin delivery is an important concept in the portable device because it should meet highly reliable control of micro fluidic delivery. In contemporary lifestyle with diabetes, Insulin delivery is best suited and preferred. The Insulin delivery system is used to deliver very small amount of liquid within the predefined time duration with constant flow rate. The user which are not able to take the dosages manually the system we are designing is very much useful for them as it automatically inject the injection in the users body and gives the particular amount of dosage and repeat the procedure after the particular time intervals.

PRESENT WORK WITH INSULIN DELIVERY SYSTEM

The paper presented by Prof. Dikondwar S. R. [1] we studied, Infusion delivery system is used to deliver

extremely small volume of liquid in predefined time duration, at a constant flow rate. Also estimation and control the infusion rate of insulin based upon relative proportional control law. It shows that the insulin delivery system which must requires the main components mini stepper motor, linear actuator, embedded controller, reciprocating pump, infusion set and glucose meter.

In the paper presented by Peter G. Jacobs, [2], we studied, the artificial pancreas system which has software application Artificial Pancreas Control (APC) which is written in C# and is wirelessly connected to system which acquires the glucagon readings which has two pumps insulin pump and glucagon pump. APC software calculates the amount of insulin and glucagon delivered to patients.

IMPORTANCE OF MICROCONTROLLER

Microcontrollers are basically binary computer . which operate on the basis of binary numbers. The binary numbers consist of only two bit 1 and 0. but we our understanding this binary is unnatural for humans to use. Assembly language is one of the best option to interface human with microcontrollers . It is therefore most basic language for controlling computers since it represents binary directly and is easier to understand. Knowledge of assembly is not completely necessary for programming the MSP430; however it is useful in optimizing routines to get the maximum performance. The c language is preferred by most of the programmer. In general, a compiler

will translate the C code into the binary code. A microcontroller is a CPU as well as it usually incorporates a range of peripherals, besides the memory and storage required to operate. We can say it is a complete computer with particular functions. In case of speed and processing capability a modern PC are too much advance, but it is very much useful in number of applications where a PC is too much.

Interfacing of stepper motor with 8051MCU

Fig. shows how to interface the Stepper Motor to microcontroller. As shown in the figure the stepper motor is connected with MCU’s output port pins through a ULN2003 motor driver. According to signals commanded by the microcontroller to ULN2003, the motor is forced to clockwise or anticlockwise direction.

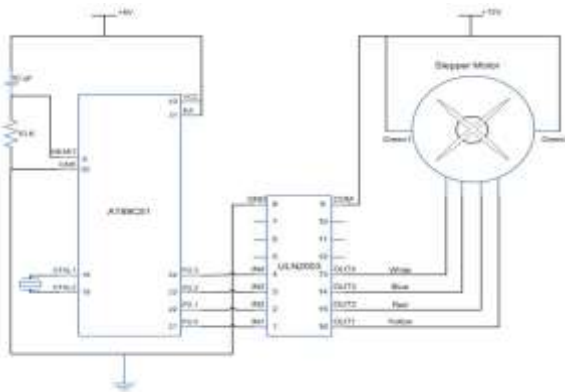

Fig.1 interfacing stepper motor with microcontroller

We now want to control a stepper motor in 8051.the motor is controlled by signals generated on the four lines of particular port. As 8051 has 4 numbers of I/O port lines, connected with any one of the I/O Port lines to rotate the stepper motor. ULN2003 is used as a driver for port I/O lines. The output of port is connected to driver but we needed an eternal power supply to drive motor through ULN2003.

Why to use msp430?

Ultra-Low Power

The MSP430 MCU is designed specifically for ultra-low-power applications. It has a flexible clocking system. Low-power modes is present. It has instant wakeup as well as intelligent autonomous peripherals which enable a real ultra-low-power optimization of a system by extending battery life.

FRAM

TI is always pushing forward with unique new technologies to decrease power consumption and increase ease-of-use. To those ends we introduce Ferroelectric Random Access Memory (FRAM). FRAM is a universal, non-volatile memory that combines the speed, endurance and flexibility of RAM with the stability and reliability of Flash all in one unified section of memory, while decreasing power consumption.

Low-Cost Options

The new MSP430 Value Line series offers ULP and 16-bit performance for low-cost, lower-end applications. Ideal for high-volume/low-cost designs, these MCUs are priced as low as 25 cents. Start developing on MSP430 Value Line devices using the \$4.30 Launch Pad development kit.

FEATURES MSP430

- Low Supply-Voltage Range: 1.8 V to 3.6 V
- Ultra-Low Power Consumption (USCI)
- Five Power-Saving Modes – Synchronous SPI
- Ultra-Fast Wake-Up From Standby Mode in – I2C™ Less Than 1 μs • On-Chip Comparator for Analog Signal
- 16-Bit RISC Architecture, 62.5-ns Instruction Compare Function or Slope Analog-to-Digital Cycle Time (A/D) Conversion
- 10-Bit 200-ksps Analog-to-Digital (A/D) Converter with Internal Frequencies up to 16 MHz With and-Hold and Auto scan Four Calibrated Frequency.

PROPOSED WORK

Basic block diagram of design and development of portable insulin system based on msp430 mcu.

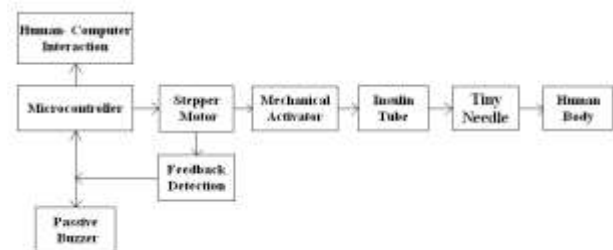

Fig2. Basic block diagram of Design and Development of Portable Insulin System Based on MSP430 MCU

- 1) Power module:

A battery with a required rated voltage is to be chosen as the supply source for the whole system.

2) The controller:

The high integration of microprocessor makes the design of a portable automatic insulin syringe with a small size possible.

3) Stepper motor:

The motor unit is the most important part of the system. Taking size and power into consideration.

4) Mechanical activator:

In this part we interfacing 2 motor with an mechanical set up to inject a needle in the human body automatically and to push insulin from insulin tube forward.

5) Insulin Tube:

It consists of insulin which is to be injected into a human body.

6) Tiny needle:

The insulin passes through this needle into veins of human body.

7) Passive buzzer:

In order to explicitly remind patients of the termination of each injection, a passive buzzer module is used to signal an alarming sound after the end of each injection.

8) Human-Computer Interaction unit:

After booting the system, the user can establish the system clock and dosage setting successively. If there's no need to change the dosage setting, a default value which is used in the previous injection will be loaded, otherwise the changed value will be written to the designated Flash unit.

Johnson, Ryan Massoud, Apurv Kamath, W. Kenneth Ward.

3. MSP430 Microcontroller Basics by John H. Davies Newnes 30 Corporate Drive, Suite 400, Burlington, MA01803, USA Linacre House, Jordan Hill, Oxford OX2 8DP, UK
4. The 8051 Microcontroller and Embedded Systems Using Assembly and C Second Edition Muhammad Ali Mazidi Janice Gillispie Mazidi Rolin D. McKinley and the 8051 Microcontroller third edition by I. Scott Mackenie.

REFERENCES

1. Volume 3, Issue 7, July 2013 ISSN: 2277 128X International Journal of Advanced Research in Computer Science and Software Engineering Research Paper Micro Flow rate Infusion Pump Prototype Prof. Smita R.Dikondwar Department of Instrumentation and Control, College of Engineering Pune, Shivaji Nagar, Pune, India.
2. Development of a fully automated closed loop artificial pancreas control system with dual pump delivery of insulin and glucagon” by Peter G. Jacobs, Member, IEEE, Joseph El Youssef, Jessica R. Castle, Julia M. Engle, Deborah L. Branigan, Phillip